

WILLBRANDT Rubber Expansion Joint Type 52

partly in stock

DN 32 - DN 600

Type 52 is a low corrugated rubber expansion joint. Due to its low corrugation, the lowest possible flow resistance is achieved. It is also characterised by its variety of lengths. Type 52 is produced in various rubber qualities, so that a suitable rubber compound is available for almost every application (see material descriptions on the following pages).

Type 52 is mainly used in industrial plants, where it is used to absorb expansion and vibrations and to dampen noise.



Bellow design	Low corrugated rubber bellow with reinforcement and shaped sealing bead with core ring, self-sealing (no additional seals required). Suitable for swiveling flanges.	Vacuum resistance	- DN 32 to 50 vakuu-proof - DN 65 to 250 up to -200 mbar - DN 300 to 600 not vacuum-proof - With vacuum supporting spiral/ring from DN 65 to DN 600 vacuum-proof
Flange version	Both sides with swiveling flange made of galvanized steel, drilled according to DIN PN 10 (standard). Other materials and dimensions are possible.	Accessories	- Tie rods - Vacuum supporting spiral/rings - Guide sleeves - PTFE lining - Potential equalisation - Flame-resistant protective covers - Dust and splash protection covers - Earth covers / sun protection covers Further information on page 99 - 105.
Pressure resistance	Max. 16 bar, depending on nominal diameter and total length		
Approvals/Conformity	CE (A2), FDA, BfR EG 1935/2004 conform		

Specifications

Bellow		Bellow design			Max. temperature °C	Permissible operating data									
Colour code	Colour marking	Core (inner)	Reinforcement	Cover (outer)		°C	bar	°C	bar	°C	bar	°C	bar	°C	bar
red		EPDM	Polyamide	EPDM	90										
yellow		NBR	Polyamide	CR	90										
green		CSM	Polyamide	CR	90										
white		NBR light	Polyamide	CR	90										
white-orange		EPDM light	Polyamide	CR	90										
red-red		EPDM	Aramid	EPDM	130										
white-blue		NBR light	Aramid	CR	120										
white-white-orange		EPDM light	Aramid	CR	130										

Operating data depend on the nominal diameter and the total length.

Important information

For aggressive media, please have the material resistance checked by our engineers. The bellows must not be painted or insulated at media temperatures >50 °C. Please also note the planning instructions (page 107 - 117).

WILLBRANDT Rubber Expansion Joint Type 52

Application

Type 52 red

For hot water, sea water, cooling water with chemical additives for treating water, saline solutions, weak acids and weak alkali solutions. Not suitable for oil products or cooling water with additives containing oil, hot air or steam.

Type 52 yellow

For oils, lubricants, fuels, gases, city and natural gas (not liquefied).

Type 52 green

For chemicals, aggressive chemical waste water and compressor air containing oil.

Type 52 white (NBR)

Like type 52 yellow, but with light-coloured internal rubber in food-grade (FDA, BfR and EG 1935/2004 conform). Not approved for drinking water.

Type 52 white-orange (EPDM)

Like type 52 red, but with light-coloured internal rubber in food-grade (FDA, BfR and EG 1935/2004 conform). Not approved for drinking water.

Type 52 red-red

Like type 52 red, but with aramid fabric.

Type 52 white-blue (NBR)

Like type 52 white, but with aramid fabric.

Type 52 white-white-orange (EPDM)

Like type 52 white-orange, but with aramid fabric.



WILLBRANDT Rubber Expansion Joint Type 52

Design A - without tie rods

Can be used for absorb movements in all directions (for combined movements, refer to the movement diagram in the technical appendix), for vibration and noise damping.

The expansion joint's reaction force must be absorbed through appropriate pipeline guidance.

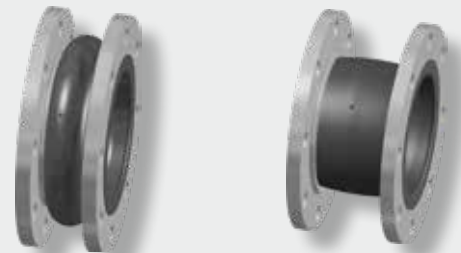
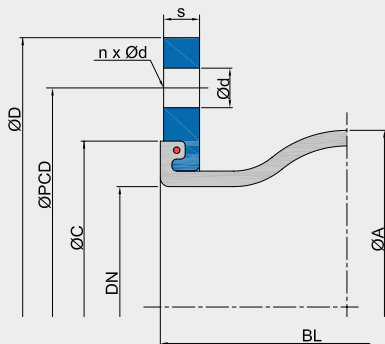

axial -

axial +



lateral ±

angular ±

Dimensions for design A

DN	Length BL mm	Bellow		Flange PN 10*2						Movement absorption*3				Weight*4 kg
		ØA mm	WF*1 mm ²	ØD mm	ØPCD mm	Ød mm	n	s mm	ØC mm	axial + mm	axial - mm	lateral ± mm	angular ± ∠°	
32	130 / 150 / 160	81	1800	140	100	18	4	15	79	10	20	15	20	3.2
40	130 / 150 / 160	86	2700	150	110	18	4	15	79	10	20	15	20	3.6
50	130 / 150 / 160	96	3200	165	125	18	4	15	88	10	20	15	20	3.8
65	130 / 150 / 160	110	5300	185	145	18	8	15	104	10	20	15	20	5.4
80	130 / 150 / 160 / 175	122	8500	200	160	18	8	15	119	15	20	15	20	7.0
100	130 / 150 / 160 / 175	142	12800	220	180	18	8	15	142	15	20	15	20	8.0
125	130 / 150 / 160 / 175	170	18700	250	210	18	8	18	169	15	20	15	20	9.7
150	130 / 150 / 160 / 175	196	25900	285	240	23	8	18	195	15	20	15	20	13.0
200	130 / 150 / 175 / 200	256	40900	340	295	23	8	20	244	15	20	15	15	16.6
250	130 / 150 / 175 / 200 / 250	306	59900	395	350	23	12	20	295	15	20	15	10	21.9
300	150 / 165 / 175 / 200	356	82200	445	400	23	12	22	351	15	20	15	10	25.2
350	200	420	117600	505	460	22	16	24	400	15	20	15	10	39.2
400	200 / 250 / 300	480	154700	565	515	26	16	25	450	15	20	15	8	43.0
450	250	530	204200	615	565	26	20	25	512	15	20	15	6	53.2
500	250	580	227900	670	620	26	20	30	563	15	20	15	4	60.0
600	250	680	311500	780	725	30	20	30	675	15	20	15	4	78.8

*1 WF = effective area

*2 Other standards/dimensions possible.

*3 Utilisation rate of movement absorption decreases at higher temperatures.

*4 For the shortest length.

Important information

Please note the appropriate fixed point constructions and plain bearings in your piping system! For more information please refer to our planning instructions. Regarding the bracing, please refer to the technical appendix.

WILLBRANDT Rubber Expansion Joint Type 52

Length limiters

A selection of different bracings is available to absorb the reaction force and to protect the bellows from overstretching or excessive compression.

Design B*

Tie rods, mounted in rubber bushing

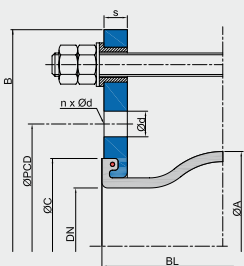

Design C*

Tie rods, mounted in rubber bushing, inside with thrust limiter (plastic bushing)

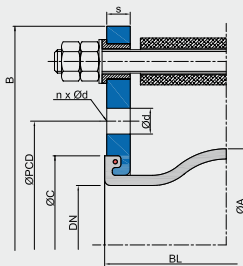

Design E

Tie rods, outside with spherical washers/conical sockets

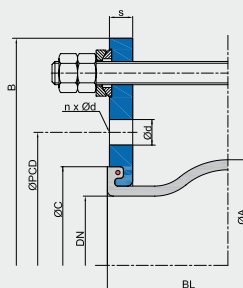

Design M

Tie rods, inside and outside with spherical washers/conical sockets

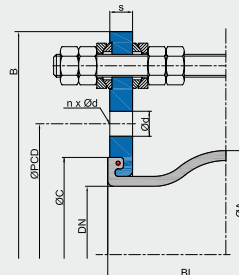

Design S

Tie rods, outside with spherical washer/conical sockets, inside with thrust limiters (plastic bushing)

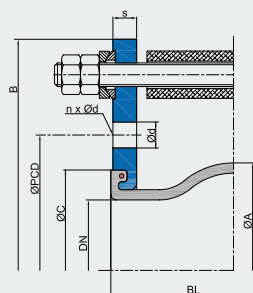

Design F

Hinge

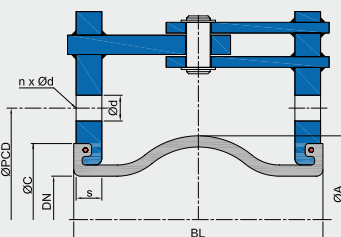

* Note: Design B and C only up to DN 200 PN 10. The lateral movement absorption is reduced by around 50 %.

Flange dimensions for designs with tie rods

DN	Flange PN 10 (example dimensions)						
	B	ØD	ØPCD	Ød	n	s	ØC
	mm	mm	mm	mm		mm	mm
32	230	140	100	18	4	15	79
40	240	150	110	18	4	15	79
50	255	165	125	18	4	16	88
65	275	185	145	18	8	16	104
80	290	200	160	18	8	18	119
100	310	220	180	18	8	18	142
125	340	250	210	18	8	18	169
150	375	285	240	23	8	18	195
200	440	340	295	23	8	20	244
250	509	395	350	23	12	20	295
300	559	445	400	23	12	22	351
350	619	505	460	22	16	24	400
400	700	565	515	26	16	25	450
450	760	615	565	26	20	30	512
500	810	670	620	26	20	30	563
600	930	780	725	30	20	30	675

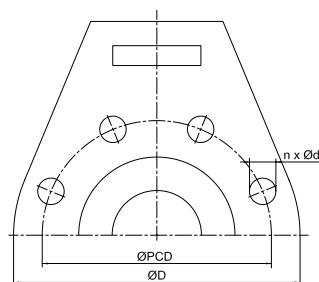
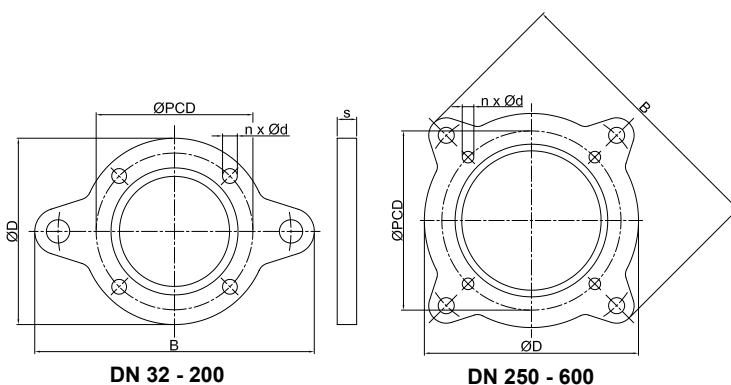

DN 50 - 600 (Design F)

WILLBRANDT Rubber Expansion Joint Type 52

Axial stiffness rates

DN	Overall length BL mm	Stiffness rates (averages value from full way)					
		0 bar N/mm	2.5 bar N/mm	4 bar N/mm	6 bar N/mm	10 bar N/mm	16 bar N/mm
32	130	54	130	245	368	466	605
40	130	56	126	237	356	451	584
50	130	47	97	187	256	330	430
65	130	61	134	252	379	480	624
80	130	82	170	305	434	543	706
100	130	95	191	315	559	743	966
125	130	111	216	419	655	863	1122
150	130	127	268	496	770	1024	1332
200	130	148	267	541	842	1089	1416
250	130	160	315	591	927	1185	1540
300	130	182	367	663	974	1307	1699
350	200	189	318	627	1018	1352	1757
400	200	200	339	671	696	1417	1842
450	250	217	416	755	1174	1511	1964
500	250	255	489	892	1378	1773	2305
600	250	270	380	900	1460	1873	2435

Warning: Deviations (+/-25 %) in the stiffness rates may occur due to use of different materials and manufacturing processes.

Lateral stiffness rates

DN	Overall length BL mm	Stiffness rates (averages value from full way)					
		0 bar N/mm	2.5 bar N/mm	4 bar N/mm	6 bar N/mm	10 bar N/mm	16 bar N/mm
32	130	85	166	240	315	346	360
40	130	81	159	232	305	335	348
50	130	65	85	104	137	189	245
65	130	52	101	150	195	215	279
80	130	46	96	177	202	225	292
100	130	72	114	186	218	250	324
125	130	130	260	339	381	498	647
150	130	156	338	402	476	606	788
200	130	420	940	1087	1234	1585	2060
250	130	492	1048	1329	1525	1923	2500
300	130	510	1088	1388	1581	2005	2606
350	200	397	793	991	1138	1427	1856
400	200	439	835	1062	1230	1559	2026
450	250	445	831	1067	1262	1560	2028
500	250	554	1063	1362	1565	1944	2527
600	250	593	1084	1381	1684	2062	2680

Warning: Deviations (+/-25 %) in the stiffness rates may occur due to use of different materials and manufacturing processes.

Important information

Please note the appropriate fixed point constructions and plain bearings in your piping system!
For more information please refer to our planning instructions. Regarding the bracing, please refer to the technical appendix.

WILLBRANDT Rubber Expansion Joint Type 52

Angular stiffness torque

DN	Overall length BL mm	Stiffness torque (averages value from full way)					
		0 bar Nm/°	2.5 bar Nm/°	4 bar Nm/°	6 bar Nm/°	10 bar N/mm	16 bar Nm/°
32	130	0.9	0.8	1.8	2.7	2.6	3.7
40	130	1	0.9	1.9	2.8	3.8	4
50	130	1	1	2	3	4	5
65	130	1	2	4	6	7	9
80	130	2	4	6	9	11	15
100	130	3	6	10	17	23	30
125	130	5	10	19	30	39	51
150	130	8	17	31	48	63	83
200	130	16	29	59	92	119	154
250	130	26	51	96	151	193	251
300	130	42	84	152	224	300	390
350	200	60	101	200	325	432	561
400	200	85	143	283	294	599	778
450	250	114	218	396	615	791	1029
500	250	162	311	567	877	1128	1467
600	250	242	339	804	1305	1674	2176

Warning: Deviations (+/-25 %) in the stiffness torque may occur due to use of different materials and manufacturing processes.

Frictional force

DN	Overall length BL mm	For design E and M	For design F
		Frictional force N/bar	Frictional moment Nm/bar
32	130	7	0.3
40	130	7	0.3
50	130	12	0.3
65	130	20	0.5
80	130	35	1.0
100	130	51	1.4
125	130	75	2.1
150	130	118	4.4
200	130	167	6.2
250	130	243	11.2
300	130	335	15.4
350	200	120	17.0
400	200	160	22.9
450	250	226	40.5
500	250	266	63.5
600	250	634	138.5

Warning: Deviations (+/-25 %) in the frictional force may occur due to use of different materials and manufacturing processes.

Important information

Please note the appropriate fixed point constructions and plain bearings in your piping system!
For more information please refer to our planning instructions. Regarding the bracing, please refer to the technical appendix.

WILLBRANDT Rubber Expansion Joint Type 52 PTFE

■ not in stock

DN 32 - DN 300

Type 52 PTFE is a low corrugated rubber expansion joint lined with PTFE. Due to its low corrugation, the lowest possible flow resistance is achieved. The PTFE lining gives the expansion joint high chemical resistance and good non-stick properties.

The PTFE lining can be used with any type 52 rubber compound. However, care must be taken to ensure that the selected rubber compound achieves the highest possible resistance to the medium, as this is the only way to achieve an optimum service life.

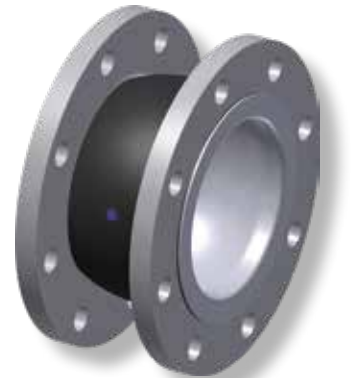

Dimensions

DN*1	Length BL	Bellows		ØD	ØPCD	Flange PN 10*3			ØC	Movement absorption			
		ØA	WF*2			Ød	n	s		axial + mm	axial - mm	lateral ± mm	angular ± ∠°
32	130	81	2700	140	100	18	4	15	79	15	15	15	10
40	130	86	2700	150	110	18	4	15	79	15	15	15	10
50	130	96	3200	165	125	18	4	15	88	15	15	15	10
65	130	110	5300	185	145	18	8	15	104	15	15	15	10
80	130	122	8500	200	160	18	8	15	119	15	15	15	10
100	130	142	12800	220	180	18	8	15	142	15	15	15	10
125	130	170	18700	250	210	18	8	18	169	15	15	15	10
150	130	196	25900	285	240	23	8	18	195	15	15	15	10
200	130	256	40900	340	295	23	8	20	244	15	15	15	4
250	130	306	59900	395	350	23	12	20	295	15	15	15	4
300	130	356	82200	445	400	23	12	22	351	15	15	15	4

*1 Larger nominal diameters possible after technical inspection.

*2 WF = effective area

*3 Other standards/dimensions possible.

Pressure resistance Max. 6 bar operating pressure with polyamide cord reinforcement, max. 9 bar operating pressure with aramid cord reinforcement

Conformity FDA and EG 1935/2004

Vacuum resistance Only limited suitable for vacuum operation. A PTFE vacuum supporting ring, which allows full vacuum for small nominal diameters, can be used from DN 50. The PTFE supporting ring can only be used up to 50 °C. DN 32 and DN 40 expansion joints are not suitable for vacuum operation.

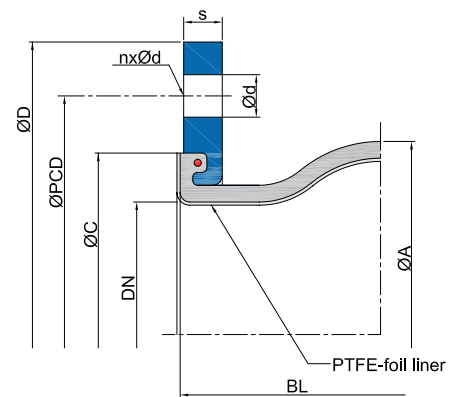

Important information

The bellows must not be painted or insulated at media temperatures >50 °C.