

WILLBRANDT Rubber Expansion Joint Type 39

■ not in stock

DN 50 to DN 600

The type 39 is a handmade, low corrugated rubber expansion joint. Its low corrugated shape minimises flow resistance. It is characterised by its flexibility in length and the wide variety of rubber qualities, so that a suitable rubber compound is available for every application (see material descriptions on the following page).

Type 39 is mainly used in plant construction and in water and wastewater technology. Here it is used especially for repairs when the gap does not correspond to a standard installation length, which means that expensive conversion work on the pipe system can be avoided. It absorbs movements and vibrations and has a noise-damping effect.



Bellow design	Low corrugated rubber bellow with reinforcement and shaped sealing bead with core ring, self-sealing (no additional seals required). Suitable for swiveling flanges.	Vacuum resistance	With appropriate design vacuum-proof.
Flange version	Both sides with swiveling flange made of galvanized steel, drilled according to DIN PN 10 (standard). Other materials and dimensions are possible.	Approvals/conformity	FDA and EG 1935/2004 conform, CE and drinking water conformity possible on request. (Detailed overview on page 5.)
Pressure resistance	Design according to customer requirements, max. 10 bar operating pressure (for higher pressures up to max. 16 bar the feasibility must be checked)	Accessories	<ul style="list-style-type: none"> - Tie rods - Vacuum supporting spiral/rings - Guide sleeves - PTFE lining (see type 39 PTFE on page 12) - Potential equalisation - Flame-resistant protective covers - Dust and splash protection covers - Earth cover / sun protection cover Further information on page 99 - 105.

Specifications

Bellow*		Bellow design*			Max. temperature °C	Permissible operating data							
Colour code	Colour marking	Core (inner)	Reinforcement	Cover (outer)		°C	bar	°C	bar	°C	bar	°C	bar
red		EPDM	Polyamide	EPDM	100								
yellow		NBR	Polyamide	NBR	90								
green		CSM	Polyamide	CSM	100								
grey		CR	Polyamide	CR	90								
red-white		EPDM light	Polyamide	EPDM	100								
yellow-white		NBR light	Polyamide	NBR	90								
lilac		FPM	Aramid	FPM	200								
-		Silicone	Aramid	Silicone	200								

* Other rubber compounds/reinforcements on request.

Important information

For aggressive media, please have the material resistance checked by our engineers. The bellows must not be painted or insulated at media temperatures >50 °C. Please also note the planning instructions and the tolerances according to the FSA manual (page 117) in the technical appendix!

WILLBRANDT Rubber Expansion Joint Type 39

Application

Type 39 red (EPDM)

For water, sea water, cooling water with glycol or other chemical additives for treating water, saline solutions, weak acids and weak alkalis. Unsuitable for aliphatic, aromatic and chlorinated hydrocarbons, oil or oily media.

Type 39 yellow (NBR)

For oils, fats, gases, diesel fuels, kerosene and crude oil. Not suitable for aromatic and chlorinated hydrocarbons, esters and ketones.

Type 39 green (CSM)

For chemicals, aggressive, chemical waste water and compressor air containing oil.

Type 39 grey (CR)

For water, waste water, swimming pool water, salt water, cooling water with anti-corrosive products containing oil, oil mixtures and compressed air containing oil.

Type 39 red-white (EPDM light)

Like type 39 red, but with light-coloured internal rubber in food-grade (FDA and EG 1935/2004 conform). Not approved for drinking water!

Type 39 yellow-white (NBR light)

Like type 39 yellow, but with light-coloured internal rubber in food-grade (FDA and EG 1935/2004 conform). Not approved for drinking water!

Type 39 lilac (FPM/aramid)

For flue gas desulphurisation systems and bio-diesel. High chemical resistance to benzene, xylene, toluene, aromatic, chlorinated hydrocarbons, mineral acids and fuels with an aromatic content of more than 50 %. Temperatures of up to +180 °C.

Type 39 silicone (silicone/aramid)

Suitable for hot air, acetic acid. Satisfactory resistance to aliphatic engine and gear oils. Also available in foodstuff quality. Excellent resistance to ageing, UV, ozone and weather. Very good resistance to radiation. No resistance for steam above 120 °C. No resistance to fuels.



WILLBRANDT Rubber Expansion Joint Type 39

Design A - without tie rods

Can be used for absorb movements in all directions (for combined movements, refer to the movement diagram in the technical appendix), for vibration and noise damping.

The expansion joint's reaction force must be absorbed through appropriate pipeline guidance (see planning instructions in the appendix).

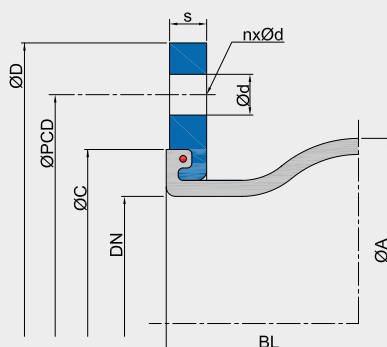

axial -



axial +



lateral ±



angular ±

Dimensions for design A (Example values - may vary depending on specification)

DN*1	Length BL*2 mm	Bellows		Flange PN 10*4						Movement absorption*5				Weight*7 kg
		ØA mm	WF*3 mm ²	ØD mm	ØPCD mm	Ød mm	n	s mm	ØC mm	axial + mm	axial - mm	lateral*6 ± mm	angular ± ∠°	
50	150 - 500	96	3200	165	125.0	18.0	4	16	86	10	20	15	35	4.1
65	150 - 500	110	5300	185	145.0	18.0	8	16	106	10	20	15	30	5.7
80	150 - 500	122	8500	200	160.0	18.0	8	18	118	15	20	15	30	7.2
100	150 - 500	142	12800	220	180.0	18.0	8	18	138	15	20	15	25	8.3
125	150 - 500	170	18700	250	210.0	18.0	8	18	166	15	20	15	25	10.0
150	150 - 500	196	25900	285	240.0	23.0	8	20	192	15	20	15	20	13.4
200	150 - 500	256	40900	340	295.0	23.0	8	20	252	15	20	15	15	16.7
250	150 - 500	306	59900	395	350.0	23.0	12	20	304	15	20	15	10	21.9
300	150 - 500	352	82200	445	400.0	23.0	12	20	354	15	20	15	10	25.0
350	150 - 500	442	108000	505	460.0	22.0	16	20	412	15	20	15	10	38.8
400	150 - 500	495	137900	565	515.0	26.0	16	25	470	20	25	20	8	38.5
450	150 - 500	545	180100	615	565.0	26.0	20	25	512	20	25	20	8	47.7
500	150 - 500	595	203800	670	620.0	26.0	20	30	570	20	25	20	6	57.2
600	150 - 500	695	328600	780	725.0	30.0	20	30	675	20	25	20	6	75.9

*1 For larger nominal diameters up to DN 1000, feasibility must be checked.

*2 Length range 150 mm to 500 mm. For larger lengths the feasibility must be checked. For smaller lengths, please also refer to our types 49, 50 and 55.

*3 The effective area (WF) and the outer diameter of the corrugation (ØA) may vary depending on the design.

*4 Other standards/dimensions possible.

*5 Utilisation rate of movement absorption decreases at higher temperatures (see technical appendix).

*6 The lateral movement absorption increases with higher length.

*7 For 200 mm length.

Table values correspond to a bellows design with 6 bar operating pressure at 60 °C.

Important information

Please note the appropriate fixed point constructions and plain bearings in your piping system, as well as the tolerances as per the FSA Handbook (see the technical appendix on page 117)! For more information please refer to our planning instructions (page 107 - 117).

WILLBRANDT Rubber Expansion Joint Type 39

Bracings

A selection of different bracings are available to absorb the reaction force and to protect the bellows from overstretching or excessive compression.

Design B*

Tie rods, mounted in rubber bushing

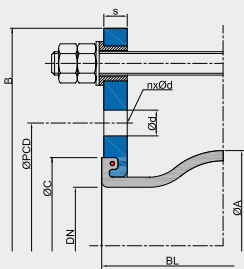

Design C*

Tie rods, mounted in rubber bushing, inside with thrust limiter (plastic bushing)

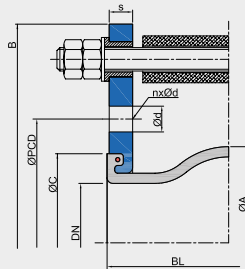

Design E

Tie rods, outside with spherical washers/conical sockets

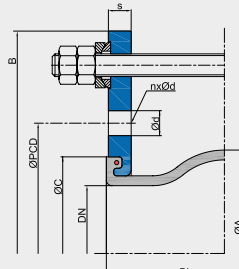

Design M

Tie rods, inside and outside with spherical washers/conical sockets

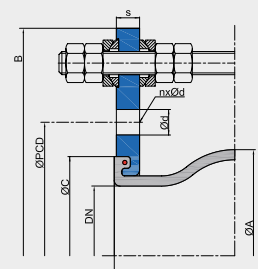

Design S

Tie rods, outside with limiters spherical washers/conical sockets, inside with thrust limiters (plastic bushing)

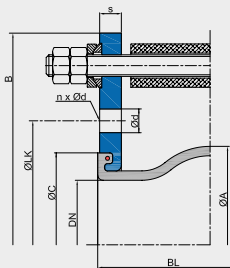

Design F

Hinge

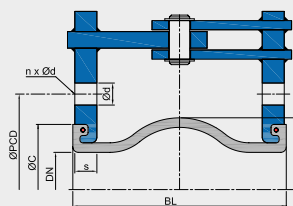

* Note: Design B and C only up to DN 200 PN 10. The lateral movement absorption is reduced by around 50 %.

Flange dimensions for designs with tie rods

DN	Length BL	Flange PN 10 (example dimensions)						
		B	ØD	ØPCD	Ød	n	s	ØC
	mm	mm	mm	mm	mm		mm	mm
50	150 - 500	255	165	125	18	4	16	86
65	150 - 500	275	185	145	18	8	16	106
80	150 - 500	290	200	160	18	8	18	118
100	150 - 500	310	220	180	18	8	18	138
125	150 - 500	340	250	210	18	8	18	166
150	150 - 500	375	285	240	23	8	20	192
200	150 - 500	440	340	295	23	8	20	252
250	150 - 500	509	395	350	23	12	20	304
300	150 - 500	559	445	400	23	12	20	354
350	150 - 500	619	505	460	22	16	20	412
400	150 - 500	700	565	515	26	16	25	470
450	150 - 500	760	615	565	26	20	25	512
500	150 - 500	810	670	620	26	20	30	570
600	150 - 500	930	780	725	30	20	30	675

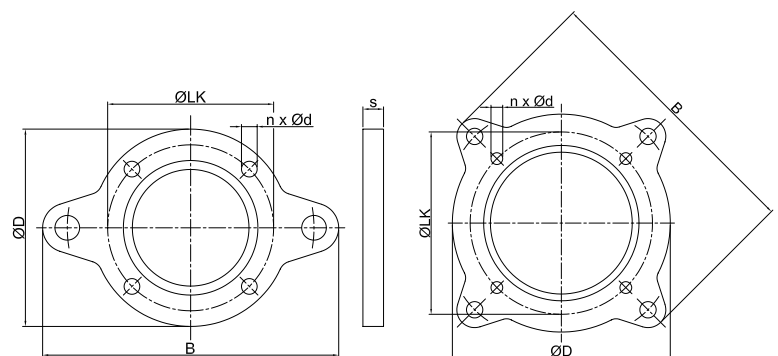

DN 50 - 200

DN 250 - 600

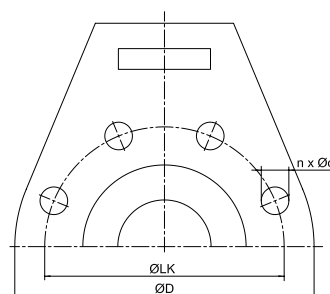

DN 50 - 600 (Design F)

Important information

For information on the tie rods, please refer to the technical appendix (page 99 - 102)!

WILLBRANDT Chemical Expansion Joint Type 39 PTFE

■ not in stock

DN 50 to DN 500

Type 39 PTFE is a low corrugated rubber expansion joint lined with PTFE. Its low corrugation minimises flow resistance. The PTFE lining gives the expansion joint good anti-adhesive properties and is chemically resistant.

The PTFE lining can be used with any Type 39 rubber compound. However, it is important to ensure that the selected rubber compound achieves the highest possible resistance to the medium, as this is the only way to achieve an optimum service life.



Dimensions for design A

DN*1	Length BL*2	Bellows		ØD	ØPCD	Flange PN 10*4				Movement absorption					
		ØA	WF*3			Ød	n	s	ØC	axial +	axial -	lateral ±	angular ± ∠°		
	mm	mm	mm ²	mm	mm	mm		mm	mm	mm	mm	mm	mm	mm	mm
50	150 - 500	96	3200	165	125	18.0	4	16	86	15	15	15	15		
65	150 - 500	110	5300	185	145	18.0	8	16	106	15	15	15	15		
80	150 - 500	122	8500	200	160	18.0	8	18	118	15	15	15	15		
100	200 - 500	142	12800	220	180	18.0	8	18	138	15	15	15	10		
125	150 - 500	170	18700	250	210	18.0	8	18	166	15	15	15	10		
150	150 - 500	196	25900	285	240	23.0	8	20	192	15	15	15	10		
200	150 - 500	256	40900	340	295	23.0	8	20	252	15	15	15	6		
250	150 - 500	306	59900	395	350	23.0	12	20	304	15	15	15	6		
300	150 - 500	352	82200	445	400	23.0	12	20	354	15	15	15	6		
350	150 - 500	442	108000	505	460	22.0	16	20	412	15	15	15	4		
400	150 - 500	495	137900	565	515	26.0	16	25	470	15	15	15	4		
450	150 - 500	545	180100	615	565	26.0	20	25	512	15	15	15	4		
500	150 - 500	595	203800	670	620	26.0	20	30	570	15	15	15	4		

*1 Larger nominal diameters possible after technical inspection.

*2 Length range 150 mm to 500 mm. For larger lengths the feasibility must be checked. For smaller lengths, please also refer to our types 50 PTFE and 55 PTFE.

*3 The effective area (WF) and the outer diameter of the corrugation (ØA) may vary depending on the design.

*4 Other standards/dimensions possible.

Table values correspond to a bellows design with 6 bar operating pressure at 60 °C.

Pressure resistance

Max. 6 bar operating pressure with polyamide cord reinforcement, max. 9 bar operating pressure with aramid cord reinforcement.

Conformity

CE (A2), FDA and EG 1935/2004
(Detailed overview on page 5.)

Vacuum resistance

Only limited suitability for vacuum operation. A PTFE vacuum supporting ring, which allows full vacuum for small nominal diameters, can be used up to DN 300. The PTFE supporting ring can only be used up to 50 °C. DN 350 expansion joints are not suitable for vacuum operation.

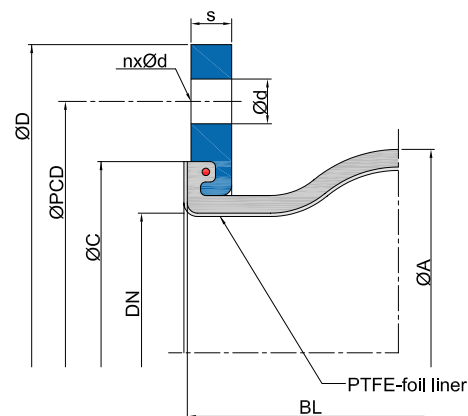

Important information

Rubber expansion joints with PTFE lining are not suitable for absorbing vibrations. The bellows must not be painted or insulated at media temperatures >50 °C. Please also note the planning instructions and the tolerances according to the FSA manual (page 117) in the technical appendix!