

# WILLBRANDT Rubber Expansion Joint Type 50

■ mainly in stock

## DN 20 to DN 1000

Type 50 is a low corrugated, highly elastic rubber expansion joint that achieves minimal flow resistance due to its flat corrugation. It reduces structure-borne noise to a high degree and is characterised by its high movement absorption in all directions. Due to the wide variety of rubber qualities, a suitable rubber compound is available for every application (see material descriptions on the following page).

Type 50 is used in building technology, plant engineering, water and wastewater technology, engine construction, shipbuilding and solar and wind energy plant construction. Here it is used specifically to absorb movement and vibrations and to dampen noise.

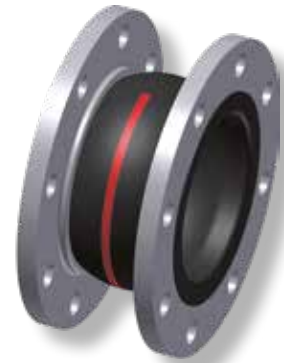

<b>Bellow design</b>	Low corrugated rubber bellow with reinforcement and shaped sealing bead with core ring, self-sealing (no additional seals required). Suitable for swiveling flanges.	<b>Vacuum resistance</b>	<ul style="list-style-type: none"> <li>- DN 20 to 50 vakuüm-proof</li> <li>- DN 65 to 250 up to -200 mbar</li> <li>- DN 300 to 1000 not vacuum-proof</li> <li>- with vacuum supporting spiral/ring from DN 65 to DN 1000 vacuum-proof</li> <li>- Type 50 black EPDM: <ul style="list-style-type: none"> <li>DN 20 to DN 40 up to -300 mbar</li> <li>from DN 50 can only be used with vacuum supporting spiral for vacuum</li> </ul> </li> </ul>
<b>Flange version</b>	Both sides with swiveling flange made of galvanized steel, drilled according to DIN PN 10 (standard). Other materials and dimensions are possible.	<b>Accessories</b>	<ul style="list-style-type: none"> <li>- Tie rods</li> <li>- Vacuum supporting spiral/rings</li> <li>- Guide sleeves</li> <li>- PTFE lining (see type 50 PTFE on page 43)</li> <li>- Potential equalisation</li> <li>- Flame-resistant protective covers</li> <li>- Dust and splash protection covers</li> <li>- Earth cover / sun protection cover</li> </ul> <p>Further information on page 99 - 105.</p>
<b>Approvals/Conformity</b>	CE, drinking water conform, shipbuilding approvals, TÜV tested in accordance with DIN 4809 (Detailed overview on page 5.)		

## Specifications for DN 20 - DN 400

Bellow	Colour code	Colour marking	Core (inner)	Bellow design	Reinforcement	Cover (outer)	up to DN	Permissible operating data								Surface resistance Ro	
								°C bar		°C bar		°C bar		°C bar		Short-term °C	Core
red Sp		■ ■ ■	EPDM	PEEK	EPDM	400	-40	10	70	16	100	10	130	8	150		
red		■	IIR	Polyamide	EPDM	400	-40	10	50	16	70	12	100	10	120	dissipative	dissipative
yellow		■	NBR	Polyamide	CR	400	-20	10	50	16	70	12	90	10	100	conductive	conductive
green		■	CSM	Polyamide	CSM	400	-20	10	50	16	70	12	100	10	110	insulating	insulating
orange		■	NBR	Polyamide	CR	200	-20	10	50	25	70	20	90	15	100	conductive	conductive
black EPDM*		◆	IIR	Polyamide	EPDM	150	-40	10	50	10	70	8	90	6	120	dissipative	dissipative
black CR		—	CR	Polyamide	CR	400	-25	10	50	16	70	12	90	10	100	insulating	insulating
yellow LT		■ LT	NBR-LT	Polyamide	CR	300	-40	10	50	16	70	12	90	10	100	dissipative	conductive
yellow St		■ ■	NBR	Steel cord	CR	400	-20	10	60	16	70	12	90	10	100	conductive	insulating
yellow HNBR		■ ■ ■	HNBR	Steel cord	CR	300	-35	10	60	16	70	12	100	10	120	dissipative	insulating

Bursting pressure DN 20 - DN 400 > 48 bar  
 \* Bursting pressure max. 30 bar, max. DN 150







For pressure loss see technical appendix.

## Important information

The expansion joints are designed for connection to a flange in accordance with EN 1092-1, form A/B, type 11. If the flange dimensions or surface finish differ from this, additional measures must be taken, such as installing an adapter disc (see also table „Rubber bellow sealing profiles“ on page 117).

# WILLBRANDT Rubber Expansion Joint Type 50

## Specifications for DN 450 - DN 1000

Bellow Colour code	Bellow Colour marking	Core (inner)	Bellow design			up to DN	Permissible operating data								Surface resistance Ro	
			Rein- forcement	Cover (outer)			°C	bar	°C	bar	°C	bar	°C	bar	Short- term °C	Core
red Sp	 	EPDM	PEEK	EPDM	1000	-40	8	70	10	100	7,5	130	6	150	dissipative	dissipative
red		IIR	Polyamide	EPDM	1000	-40	8	50	10	70	8	100	6	120	dissipative	dissipative
yellow		NBR	Polyamide	CR	1000	-20	8	50	10	70	8	90	6	100	conductive	conductive
green		CSM	Polyamide	CSM	600	-20	8	50	10	70	8	90	6	100	insulating	insulating
black CR	—	CRN	Polyamide	CR	1000	-25	8	50	10	70	8	90	6	110	insulating	insulating
yellow St	 	NBR	Steel cord	CR	600	-20	8	60	10	70	8	90	6	100	conductive	insulating

Bursting pressure DN 450 - 1000 > 30 bar

For pressure loss see technical appendix.

## Application

### Type 50 red Sp

For heating installations according to DIN 4809. For many years of operation under constant loading with hot water and heating water at 100 °C/110 °C at 10 bar/6 bar operating pressure. Electrically dissipative surface. Not suitable for media with additives containing oil.

### Type 50 red

For drinking water, hot water, sea water, cooling water with glycol or other chemical additives for treating water, weak acids and weak alkalis and salt solutions, technical alcohols, esters, ketones. Electrically dissipative surface. Not suitable for oil products or cooling water with additives containing oil.

### Type 50 yellow

For oils, lubricants, fuels, gases, city and natural gas (not liquefied) and DIN EN fuels with an aromatic content up to 50 %. Electrically conductive surface.

### Type 50 green

For chemicals, aggressive chemical waste water and compressor air containing oil. Electrically insulating surface.

### Type 50 orange

Like type 50 yellow, but for 25 bar operating pressure und for liquid petroleum gas acc. to DIN EN 589. Electrically conductive surface.

### Type 50 black EPDM

Like type 50 red, but but max. 10 bar operating pressure.

### Type 50 black CR

For cold and hot water, swimming pool water, sald water, waste water, cooling water with coolant (e.g. glycol up to 60 °C) and anti-corrosive products containing oil, oil mixtures and compressed air containing oil. Electrically insulating surface.

### Type 50 yellow LT

Like type 50 yellow, but also for liquid gas. Electrically dissipate inner surface and electrically conductive outer surface.

### Type 50 yellow St

Like type 50 yellow with additional flame-resistance for up to 30 minutes at 800 °C. Electrically conductive inner surface and electrically insulating outer surface.

### Type 50 yellow HNBR

Like type 50 yellow St, but for temperatures up to +100 °C. Electrically dissipative inner surface and electrically insulating outer surface.

## Important information

The expansion joints are designed for connection to a flange in accordance with EN 1092-1, form A/B, type 11. If the flange dimensions or surface finish differ from this, additional measures must be taken, such as installing an adapter disc (see also table „Rubber bellow sealing profiles“ on page 117).

For aggressive media, please have the material resistance checked by our engineers. The bellows must not be painted or insulated at media temperatures >50 °C. Please also note the planning instructions.

# WILLBRANDT Rubber Expansion Joint Type 50

## Design A - without tie rods

Can be used for absorb movements in all directions (for combined movements, refer to the movement diagram in the technical appendix), for vibration and noise damping.

The expansion joint's reaction force must be absorbed through appropriate pipeline guidance (see planning instructions in the appendix).

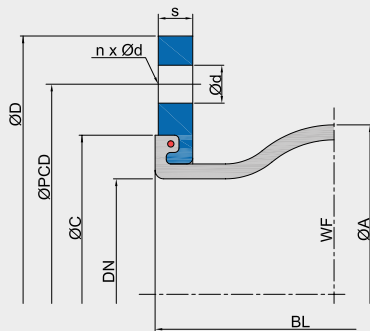

## Dimensions for design A

DN	Length BL	Bellow		Flange PN 10*2						Movement absorption*3 (polyamide cord)				Movement absorption*3 (steel cord)				Weight*4 kg
		ØA	WF*1	ØD	ØPCD	Ød	n	s	ØC	axial + mm	axial - mm	lateral ± mm	angular ± ∠°	axial + mm	axial - mm	lateral ± mm	angular ± ∠°	
*520	130	81	1700	105	75	M12	4	14	66	30	30	30	30	15	30	15	20	1.6
25	130	81	1700	115	85	14	4	14	66	30	30	30	30	15	30	15	20	1.8
32	130	81	1700	140	100	18	4	15	66	30	30	30	30	15	30	15	20	2.9
40	130	86	1800	150	110	18	4	15	74	30	30	30	30	15	30	15	20	3.4
50	130	96	3200	165	125	18	4	16	86	30	30	30	30	15	30	15	20	4.5
65	130	111	5300	185	145	18	8	16	106	30	30	30	30	15	30	15	20	5.2
80	130	122	8500	200	160	18	8	18	118	30	30	30	30	15	30	15	20	6.6
100	130	142	12800	220	180	18	8	18	138	30	30	30	20	15	30	15	15	7.6
125	130	168	18700	250	210	18	8	18	166	30	30	30	20	15	30	15	15	9.4
150	130	192	25900	285	240	22	8	18	192	30	30	30	20	15	30	15	15	11.7
200	130	252	41000	340	295	22	8	20	252	30	30	30	10	20	15	10	15	16.0
250	130	302	59600	395	350	22	12	20	304	30	20	20	5	20	15	10	15	18.7
300	130	354	82200	445	400	22	12	22	354	30	20	20	5	20	15	10	15	24.2
350	200	420	117600	505	460	22	16	24	412	35	50	30	8	30	30	25	10	40.0
400	200	480	154700	565	515	26	16	25	470	35	50	30	8	30	40	25	15	45.6
450	200	530	204200	615	565	26	20	28	520	35	50	30	8	-	-	-	-	57.0
500	200	580	227900	670	620	26	20	30	570	35	50	30	8	-	-	-	-	67.4
600	200	680	311500	780	725	30	20	30	675	35	40	30	8	-	-	-	-	81.3
700	*6250	800	434200	895	840	30	24	35	780	40	30	30	5	-	-	-	-	121.7
800	250	880	527400	1015	950	33	24	40	887	35	40	35	5	-	-	-	-	159.7
900	300	1038	737900	1115	1050	33	28	40	987	40	40	40	5	-	-	-	-	197.0
1000	300	1138	889400	1230	1160	36	28	40	1087	40	40	40	5	-	-	-	-	237.0

\*1 WF = effective area

\*2 Other standards/dimensions possible.

\*3 Utilisation rate of movement absorption decreases at higher temperatures (see technical appendix).

\*4 Approx. weights with reinforcement from polyamide cord, with steel cord approx. + 3 - 7 %.

\*5 Flange with threaded holes

\*6 Building length 260 mm

## Important information

Please note the appropriate fixed point constructions and plain bearings in your piping system! Information on this can be found in our planning instructions.

Regarding the bracing, please refer to the information in the technical appendix (page 99 - 102)!

# WILLBRANDT Rubber Expansion Joint Type 50

## Bracings

A selection of different bracings are available to absorb the reaction force and to protect the bellows from overstretching or excessive compression.

### Design B\*

Tie rods, mounted in rubber bushing

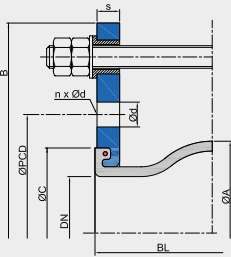

### Design C\*

Tie rods, mounted in rubber bushing, inside with thrust limiter (plastic bushing)

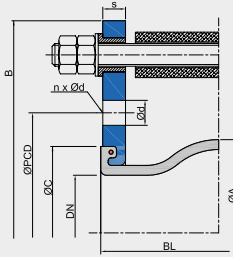

### Design E

Tie rods, outside with spherical washers/conical sockets

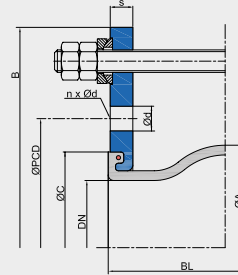

### Design M

Tie rods, inside and outside with spherical washers/conical sockets

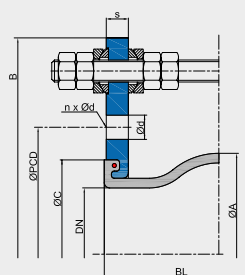

### Design S

Tie rods, outside with limiters spherical washers/conical sockets, inside with thrust limiters (plastic bushing)

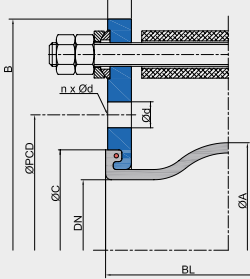

### Design F

Hinge

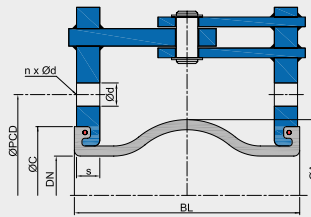

\* Note: Design B and C only up to DN 200 PN 10. The lateral movement absorption is reduced by around 50 %.

## Flange dimensions for designs with tie rods

DN	Length BL	Flange PN 10 (example dimensions)						
		B	ØD	ØPCD	Ød	n	s	ØC
	mm	mm	mm	mm	mm		mm	mm
20	130	189	105	75	M12	4	14	66
25	130	205	115	85	14	4	14	66
32	130	230	140	100	18	4	15	66
40	130	240	150	110	18	4	15	74
50	130	255	165	125	18	4	16	86
65	130	275	185	145	18	8	16	106
80	130	290	200	160	18	8	18	118
100	130	310	220	180	18	8	18	138
125	130	340	250	210	18	8	18	166
150	130	375	285	240	22	8	18	192
200	130	440	340	295	22	8	20	252
250	130	509	395	350	22	12	20	304
300	130	559	445	400	22	12	22	354
350	200	619	505	460	22	16	24	412
400	200	700	565	515	26	16	25	470
450	200	760	615	565	26	20	30	520
500	200	810	670	620	26	20	30	570
600	200	930	780	725	30	20	30	675
700	*250	1045	895	840	30	24	35	780
800	250	1175	1015	950	33	24	40	887
900	300	1285	1115	1050	33	28	40	987
1000	300	1400	1230	1160	36	28	40	1087

\* Building length 260 mm

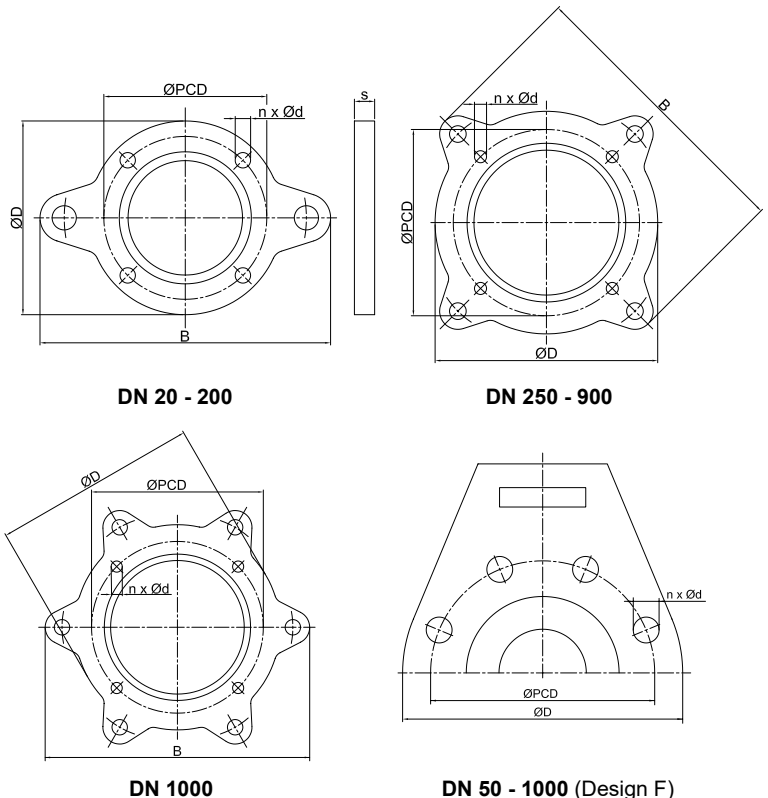

# WILLBRANDT Rubber Expansion Joint Type 50

## Axial stiffness rates

DN	Length BL mm	Stiffness rates (averages value from full way)					
		0 bar N/mm	2,5 bar N/mm	4 bar N/mm	6 bar N/mm	10 bar N/mm	16 bar N/mm
20	130	31	68	128	192	243	270
25	130	31	68	128	192	243	270
32	130	31	68	128	192	243	270
40	130	30	66	124	186	236	261
50	130	25	51	98	134	173	192
65	130	24	53	100	150	190	211
80	130	28	58	104	148	185	205
100	130	35	71	116	206	274	304
125	130	36	71	137	214	282	313
150	130	49	102	189	293	390	433
200	130	100	180	365	568	735	816
250	130	105	207	388	609	778	864
300	130	123	248	448	658	883	980
350	200	105	177	349	567	753	836
400	200	154	261	516	535	1090	1210
450	200	167	320	581	903	1162	-
500	200	196	376	686	1060	1364	-
600	200	208	292	692	1123	1441	-
700	*250	140	198	521	714	954	-
800	250	180	270	594	975	1258	-
900	300	200	380	690	1080	1395	-
1000	300	225	420	742	1248	1568	-

\* Building length 260 mm

Warning: Deviations (+/- 25 %) in the stiffness rates may occur due to use of different materials and manufacturing processes.

## Lateral stiffness rates

DN	Length BL mm	Stiffness rates (averages value from full way)					
		0 bar N/mm	2,5 bar N/mm	4 bar N/mm	6 bar N/mm	10 bar N/mm	16 bar N/mm
20	130	64	125	184	240	240	300
25	130	64	125	184	240	240	300
32	130	64	125	184	240	240	300
40	130	62	121	178	233	256	291
50	130	50	65	80	105	145	205
65	130	40	78	115	150	165	188
80	130	35	74	136	155	173	200
100	130	55	88	143	168	192	228
125	130	100	200	261	293	383	518
150	130	120	260	309	366	466	616
200	130	323	723	836	949	1219	1624
250	130	379	806	1022	1173	1479	1938
300	130	392	837	1068	1216	1542	2031
350	200	305	610	762	875	1098	1433
400	200	338	642	817	946	1199	1579
450	200	342	639	821	971	1200	-
500	200	426	818	1048	1204	1495	-
600	200	456	834	1062	1295	1586	-
700	*250	516	939	1191	1449	1775	-
800	250	558	960	1055	1557	1758	-
900	300	800	1480	1984	2248	2560	-
1000	300	960	1824	2361	2736	2976	-

\* Building length 260 mm

Warning: Deviations (+/- 25 %) in the stiffness rates may occur due to use of different materials and manufacturing processes.



## WILLBRANDT Rubber Expansion Joint Type 50

### Angular stiffness torque

DN	Length BL mm	Stiffness torque (averages value from full way)					
		0 bar Nm/°	2,5 bar Nm/°	4 bar Nm/°	6 bar Nm/°	10 bar Nm/°	16 bar Nm/°
20	130	0.2	0.5	0.9	1.3	1.7	1.9
25	130	0.2	0.5	0.9	1.3	1.7	1.9
32	130	0.2	0.5	0.9	1.3	1.7	1.9
40	130	0.3	0.6	1.1	1.6	2.0	2.3
50	130	0.3	0.6	1.1	1.6	2.0	2.2
65	130	0.4	0.9	1.7	2.5	3.2	3.6
80	130	1.0	1.0	2.0	3.0	4.0	5.0
100	130	1.0	2.0	4.0	7.0	9.0	10.0
125	130	2.0	3.0	6.0	10.0	13.0	15.0
150	130	3.0	7.0	12.0	19.0	25.0	28.0
200	130	11.0	20.0	41.0	63.0	82.0	91.0
250	130	18.0	35.0	65.0	102.0	130.0	144.0
300	130	29.0	58.0	105.0	154.0	206.0	229.0
350	200	34.0	57.0	113.0	183.0	244.0	270.0
400	200	65.0	110.0	218.0	226.0	460.0	511.0
450	200	87.0	168.0	304.0	473.0	609.0	-
500	200	125.0	239.0	436.0	674.0	868.0	-
600	200	186.0	261.0	618.0	1004.0	1288.0	-
700	*250	167.0	237.0	861.0	853.0	1140.0	-
800	250	277.0	416.0	914.0	1501.0	1937.0	-
900	300	386.0	733.0	1330.0	2082.0	2689.0	-
1000	300	531.0	991.0	1751.0	2945.0	3700.0	-

\* Building length 260 m

Warning: Deviations (+/- 25 %) in the stiffness torque may occur due to use of different materials and manufacturing processes.

### Frictional force

DN	Length BL mm	For designs E and M	For design F
		Frictional force N/bar	Frictional torque Nm/bar
20	130	7	0.2
25	130	7	0.2
32	130	7	0.2
40	130	7	0.2
50	130	12	0.3
65	130	20	0.5
80	130	35	1.0
100	130	51	1.4
125	130	75	2.1
150	130	118	4.4
200	130	167	6.2
250	130	243	11.2
300	130	335	15.4
350	200	120	17.0
400	200	160	22.9
450	200	171	40.5
500	200	266	63.5
600	200	634	138.5
700	*250	662	180.9
800	250	896	326.2
900	250	1105	402.4
1000	250	1357	617.3

\* Building length 260 m

Warning: Deviations (+/- 25 %) in the frictional force/torque may occur due to use of different materials and manufacturing processes.



