

WILLBRANDT Rubber Expansion Joint Type 55

■ mainly in stock

DN 20 to DN 1000

Type 55 is a low corrugated, highly elastic rubber expansion joint that achieves minimal flow resistance due to its flat corrugation. It reduces structure-borne noise to a high degree and is characterised by its high movement absorption in all directions. Due to the wide variety of rubber qualities, a suitable rubber compound is available for every application (see material descriptions on the following page).

Type 55 is used in building technology, plant engineering, water and wastewater technology, engine construction, shipbuilding and solar and wind energy plant construction. Here it is used specifically to absorb movement and vibrations and to dampen noise.



Bellow design	Low corrugated rubber bellow with reinforcement and shaped sealing bead with core ring, self-sealing (no additional seals required). Suitable for swiveling flanges.	Vacuum resistance	<ul style="list-style-type: none"> - DN 20 to 50 vacuum-proof - DN 65 to 250 up to -200 mbar - DN 300 to 1000 not vacuum-proof - With vacuum supporting spiral/ring from DN 65 to DN 1000 vacuum-proof
Flange version	Both sides with swiveling flange made of galvanized steel, drilled according to DIN PN 10 (standard). Other materials and dimensions are possible.	Accessories	<ul style="list-style-type: none"> - Tie rods - Vacuum supporting spiral/rings - Guide sleeves - PTFE lining (see type 55 PTFE on page 66) - Potential equalisation - Flame-resistant protective covers - Dust and splash protection covers - Earth cover / sun protection cover Further information on page 99 - 105.
Approvals/Conformity	CE, drinking water conform, shipbuilding approvals, TÜV tested in accordance with DIN 4809 (Detailed overview on page 5.)		

Specifications for DN 20 - DN 400

Bellow		Bellow design			Permissible operating data								Surface resistance Ro		
Colour-code	Colour marking	Core (inner)	Reinforcement	Cover (outer)	°C		°C		°C		°C		Short-term °C	Core	Cover
red Sp	■ ■	EPDM	PEEK	EPDM	-40	10	70	16	100	10	130	8	150	dissipative	dissipative
red	■	IIR	Polyamide	EPDM	-40	10	50	16	70	12	100	10	120	dissipative	dissipative
yellow	■	NBR	Polyamide	CR	-20	10	50	16	70	12	90	10	100	conductive	conductive
green	■	CSM	Polyamide	CSM	-20	10	50	16	70	12	100	10	110	insulating	insulating
yellow St	■ ■	NBR	Steel cord	CR	-20	10	60	16	70	12	90	10	100	conductive	insulating

Bursting pressure for DN 20 - 400: > 48 bar
 DN 300 max. 10 bar working pressure / Bursting pressure >30 bar

Specifications for DN 450 - DN 1000

Bellow		Bellow design			Permissible operating data								Surface resistance Ro		
Colour-code	Colour marking	Core (inner)	Reinforcement	Cover (outer)	°C		°C		°C		°C		Short-term °C	Core	Cover
red Sp	■ ■	EPDM	PEEK	EPDM	-40	8	70	10	100	7.5	130	6	150	dissipative	dissipative
red	■	IIR	Polyamide	EPDM	-40	8	50	10	70	8.0	100	6	120	dissipative	dissipative
yellow	■	NBR	Polyamide	CR	-20	8	50	10	70	8.0	90	6	100	conductive	conductive
green	■	CSM	Polyamide	CSM	-20	8	50	10	70	8.0	100	6	110	insulating	insulating

Bursting pressure for DN 450 - 1000: > 30 bar
 DN 450 only available in red or yellow.

Important information

The expansion joints are designed for connection to a flange in accordance with EN 1092-1, form A/B, type 11. If the flange dimensions or surface finish differ from this, additional measures must be taken, such as installing an adapter disc (see also table „Rubber bellow sealing profiles“ on page 117).

WILLBRANDT Rubber Expansion Joint Type 55

Application

Type 55 red Sp

For heating installations according to DIN 4809. For many years of operation under constant loading with hot water and heating water at 100 °C/110 °C at 10 bar/6 bar operating pressure. Electrically dissipative surface. Not suitable for media with additives containing oil.

Type 55 red

For drinking water, hot water, sea water, cooling water with glycol or other chemical additives for treating water, weak acids and weak alkalis, salt solutions, technical alcohols, esters and ketones. Electrically dissipative surface. Not suitable for oil products or cooling water with additives containing oil.

Type 55 yellow

For oils, lubricants, fuels, gases, city and natural gas (not liquefied) and DIN EN fuels with an aromatic content up to 50 %. Electrically conductive surface.

Type 55 green

For chemicals, aggressive chemical waste water and compressor air containing oil. Electrically insulating surface.

Type 55 yellow St

Like type 55 yellow with additional flame-resistance for up to 30 minutes at 800 °C. Electrically conductive inner surface and electrically insulating outer surface.

Important information

For aggressive media, please have the material resistance checked by our engineers.
The bellows must not be painted or insulated at media temperatures >50 °C.
Please also note the planning instructions.



WILLBRANDT Rubber Expansion Joint Type 55

Design A - without tie rods

Can be used for absorb movements in all directions (for combined movements, refer to the movement diagram in the technical appendix), for vibration and noise damping.

The expansion joint's reaction force must be absorbed through appropriate pipeline guidance (see planning instructions in the appendix).

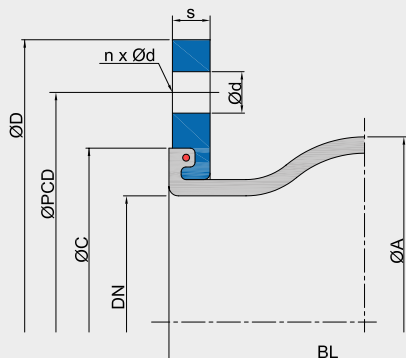

Dimensions for design A

DN	Length BL mm	Bellow		Flansch PN 10*2						Movement absorption*3 (Polyamide cord)				Movement absorption*3 (Steel cord)				Weight*4 kg
		ØA mm	WF*1 mm ²	ØD mm	ØPCD mm	Ød mm	n	s mm	ØC mm	axial + mm	axial - mm	lateral ± mm	angular ± ∠°	axial + mm	axial - mm	lateral ± mm	angular ± ∠°	
*520	*6125	81	1700	105	75	M12	4	14	66	35	25	30	30	15	30	15	20	1.6
25	*6125	81	1700	115	85	14	4	14	66	35	25	30	30	15	30	15	20	1.8
32	*6125	81	1700	140	100	18	4	15	66	35	25	30	30	15	30	15	20	2.9
40	*6125	86	1800	150	110	18	4	15	74	35	25	30	30	15	30	15	20	3.4
50	*6125/*7150	96	3200	165	125	18	4	16	86	35/30	25/35	30	30/15	15	30	15	20	4.5
65	*6125/*7150	111	5300	185	145	18	8	16	106	35/30	25/35	30	30/15	15	30	15	20	5.2
80	150	122	8500	200	160	18	8	18	118	30	35	30	30	20	35	15	15	6.7
100	150	142	12800	220	180	18	8	18	138	30	35	30	20	20	35	15	15	7.7
125	150	168	18700	250	210	18	8	18	166	30	35	30	20	20	35	15	15	9.4
150	150	192	25900	285	240	22	8	18	192	30	35	30	20	20	35	15	15	11.7
200	150/*7175	252	41000	340	295	22	8	20	252	30/35	15	30/15	15/5	20	25	15	15	16.2
250	175	302	59600	395	350	22	12	20	304	35	15	15	5	20	25	15	15	22.8
300	200	354	82200	445	400	22	12	22	354	35	40	30	10	30	30	25	10	27.7
350	200	420	117600	505	460	22	16	24	412	35	40	30	8	30	30	25	10	40.0
400	200	480	154700	565	515	26	16	25	470	35	40	30	8	30	40	25	15	45.6
*8450	250	530	204200	615	565	26	20	25	520	35	40	35	10	-	-	-	-	57.9
*9500	-	-	-	-	-	-	-	-	-	-	-	-	-	-	-	-	-	-
*9600	-	-	-	-	-	-	-	-	-	-	-	-	-	-	-	-	-	-
700	*10275	800	434200	895	840	30	24	35	780	15	55	30	5	-	-	-	-	121.8
800	250	880	527400	1015	950	33	24	40	887	35	40	35	5	-	-	-	-	159.7
900	300	1038	737900	1115	1050	33	28	40	987	40	40	40	5	-	-	-	-	197.0
1000	300	1138	889400	1230	1160	36	28	40	1087	40	40	40	5	-	-	-	-	237.0

*1 WF = effective area

*2 Other standards/dimensions possible.

*3 Utilisation rate of movement absorption decreases at higher temperatures (see technical appendix).

*4 Approx. weights with reinforcement from polyamide cord, with steel cord approx. + 3 - 7 %.

*5 Flange with threaded holes.

*6 Building length 130 mm

*7 BL 150: only in red (IIR) or yellow (NBR) available.

*8 Only in colour code red (IIR) and yellow (NBR).

*9 See type 39 and type 52

*10 Building length 260 mm

Important information

Please note the appropriate fixed point constructions and plain bearings in your piping system! Information on this can be found in our planning instructions. Regarding the bracing, please refer to the information in the technical appendix (page 99 - 102).

WILLBRANDT Rubber Expansion Joint Type 55

Bracings

A selection of different bracings are available to absorb the reaction force and to protect the bellows from overstretching or excessive compression.

Design B*

Tie rods, mounted in rubber bushing

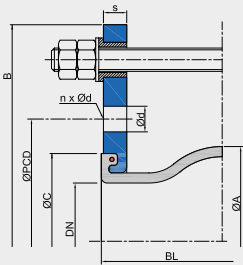

Design C*

Tie rods, mounted in rubber bushing, inside with thrust limiter (plastic bushing)

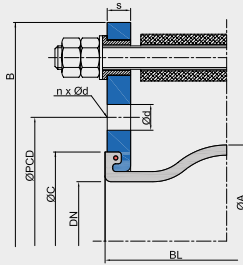

Design E

Tie rods, outside with spherical washers/conical sockets

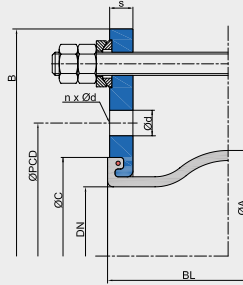

Design M

Tie rods, inside and outside with spherical washers/conical sockets

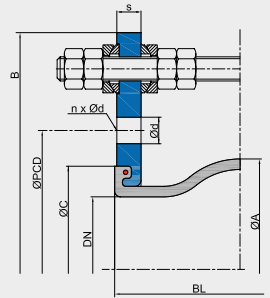

Design S

Tie rods, outside with limiters spherical washers/conical sockets, inside with thrust limiters (plastic bushing)

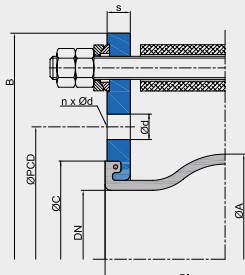

Design F

Hinge

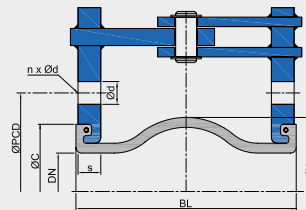

* Note: Design B and C only up to DN 200 PN 10. The lateral movement absorption is reduced by around 50 %.

Flange dimensions for designs with tie rods

DN	Length BL	B	Flange PN 10 (example dimensions)						ØC
			ØD	ØPCD	Ød	n	s		
20	*1125	189	105	75	M12	4	14	66	
25	*1125	205	115	85	14	4	14	66	
32	*1125	230	140	100	18	4	15	66	
40	*1125	240	150	110	18	4	15	74	
50	*1125/150	255	165	125	18	4	16	86	
65	*1125/150	275	185	145	18	8	16	106	
80	150	290	200	160	18	8	18	118	
100	150	310	220	180	18	8	18	138	
125	150	340	250	210	18	8	18	166	
150	150	375	285	240	22	8	18	192	
200	175/150	440	340	295	22	8	20	252	
250	175	509	395	350	22	12	20	304	
300	200	559	445	400	22	12	22	354	
350	200	619	505	460	22	16	24	412	
400	200	700	565	515	26	16	25	470	
450	250	760	615	565	26	20	30	520	
700	*2275	1045	895	840	30	24	35	780	
800	250	1175	1015	950	33	24	40	887	
900	300	1285	1115	1050	33	28	40	987	
1000	300	1400	1230	1160	36	28	40	1087	

*1 Building length 130 mm
*2 Building length 260 mm

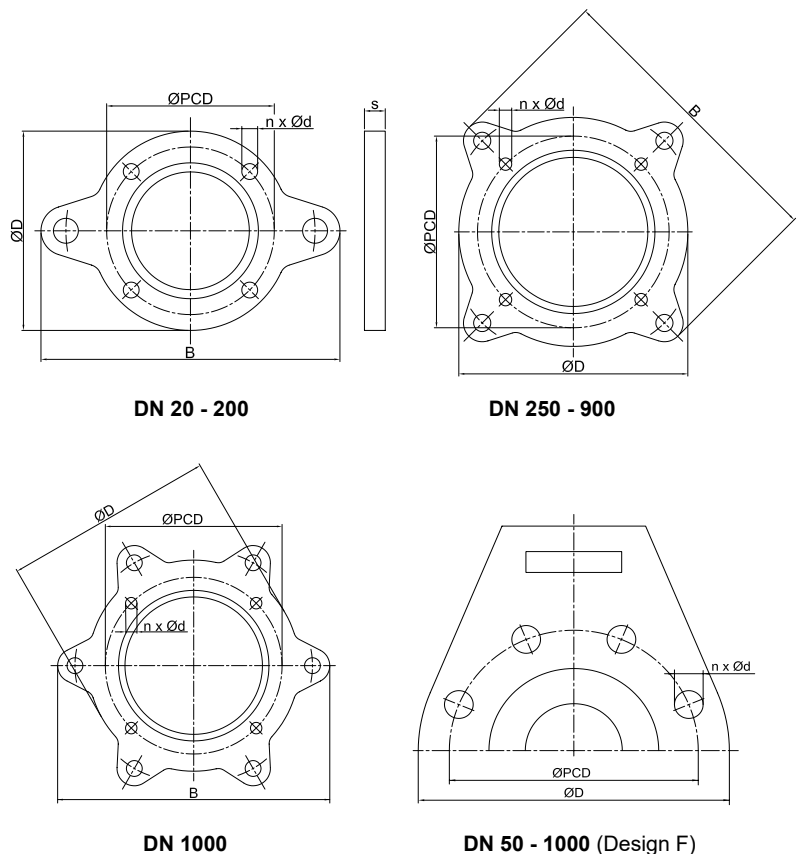

WILLBRANDT Rubber Expansion Joint Type 55

Axial stiffness rates

DN	Length BL mm	Stiffness rates (average value from full way)										
		0 bar N/mm	1 bar N/mm	2.5 bar N/mm	3 bar N/mm	4 bar N/mm	5 bar N/mm	6 bar N/mm	8 bar N/mm	10 bar N/mm	12 bar N/mm	16 bar N/mm
20	*1125	31	56	68	88	128	160	192	192	243	252	270
25	*1125	31	56	68	88	128	160	192	192	243	252	270
32	*1125	31	56	68	88	128	160	192	192	243	252	270
40	*1125	30	54	66	85	124	155	186	186	236	244	261
50	*1125/150	25	42	51	67	98	116	134	134	173	179	192
65	*1125/150	24	43	53	69	100	125	150	150	190	197	211
80	150	28	48	58	73	104	126	148	148	185	192	205
100	150	35	59	71	86	116	161	206	206	274	284	304
125	150	36	59	71	93	137	176	214	214	282	292	313
150	150	49	84	102	131	189	241	293	293	390	404	433
200	175/150	100	153	180	242	365	467	568	568	735	762	816
250	175	105	173	207	267	388	499	609	609	778	807	864
300	200	123	206	248	315	448	553	658	659	883	915	980
350	200	105	153	177	234	349	458	567	567	753	781	836
400	200	154	225	261	346	516	526	535	536	1090	1130	1210
450	250	167	269	320	407	581	742	903	904	1162	-	-
700	*2275	140	179	198	372	721	718	714	715	954	-	-
800	250	180	240	270	378	594	785	975	976	1258	-	-
900	300	200	320	380	483	690	885	1080	1081	1395	-	-
1000	300	225	355	420	527	742	995	1248	1249	1568	-	-

*1 Building length 130 mm

*2 Building length 260 mm

Warning: Deviations (+/-25 %) in the stiffness rates may occur due to use of different materials and manufacturing processes.

Lateral stiffness rates

DN	Length BL mm	Stiffness rates (average value from full way)										
		0 bar N/mm	1 bar N/mm	2.5 bar N/mm	3 bar N/mm	4 bar N/mm	5 bar N/mm	6 bar N/mm	8 bar N/mm	10 bar N/mm	12 bar N/mm	16 bar N/mm
20	*1125	64	105	125	145	184	212	240	249	259	260	264
25	*1125	64	105	125	145	184	212	240	249	259	260	264
32	*1125	64	105	125	145	184	212	240	249	259	260	264
40	*1125	62	101	121	140	178	205	233	242	251	252	256
50	*1125/150	50	60	65	70	80	93	105	124	142	143	145
65	*1125/150	40	65	78	90	115	133	150	156	162	163	165
80	150	34	59	72	92	132	141	151	158	165	166	168
100	150	53	74	85	102	138	150	162	172	181	183	185
125	150	97	162	194	214	253	269	284	324	364	367	372
150	150	116	206	251	267	299	326	354	398	441	444	450
200	175/150	304	555	680	716	787	840	893	1009	1124	1132	1147
250	175	356	624	758	826	961	1032	1103	1233	1363	1373	1391
300	200	368	647	786	858	1003	1072	1142	1280	1419	1428	1448
350	200	305	508	610	661	762	819	875	976	1076	1083	1098
400	200	338	541	642	700	817	882	946	1061	1175	1183	1199
450	250	342	540	639	700	821	896	971	1074	1176	-	-
700	*2275	516	798	939	1023	1191	1320	1449	1594	1740	-	-
800	250	558	826	960	992	1055	1306	1557	1640	1723	-	-
900	300	800	1253	1480	1648	1984	2116	2248	2378	2509	-	-
1000	300	960	1536	1824	2003	2361	2549	2736	2826	2916	-	-

*1 Building length 130 mm

*2 Building length 260 mm

Warning: Deviations (+/-25 %) in the stiffness rates may occur due to use of different materials and manufacturing processes.



WILLBRANDT Rubber Expansion Joint Type 55

Angular stiffness torque

DN	Length BL mm	Stiffness torque (average value from full way)					
		0 bar Nm/°	2.5 bar Nm/°	4 bar Nm/°	6 bar Nm/°	10 bar Nm/°	16 bar Nm/°
20	*1125	0.2	0.5	0.9	1.3	1.7	1.9
25	*1125	0.2	0.5	0.9	1.3	1.7	1.9
32	*1125	0.2	0.5	0.9	1.3	1.7	1.9
40	*1125	0.3	0.6	1.1	1.6	2.0	2.3
50	*1125	0.3	0.6	1.1	1.6	2.0	2.2
65	*1125	0.4	0.9	1.7	2.5	3.2	3.6
80	150	0.6	1.3	2.3	3.3	4.1	4.6
100	150	1.0	2.0	4.0	7.0	9.0	10.0
125	150	2.0	3.0	6.0	10.0	13.0	15.0
150	150	3.0	7.0	12.0	19.0	25.0	28.0
200	175	11.0	20.0	41.0	63.0	82.0	91.0
250	175	18.0	35.0	65.0	102.0	130.0	144.0
300	200	29.0	58.0	105.0	154.0	206.0	229.0
350	200	34.0	57.0	113.0	183.0	244.0	270.0
400	200	65.0	110.0	218.0	226.0	460.0	511.0
450	250	114.0	218.0	396.0	615.0	792.0	-
700	*2275	167.0	237.0	861.0	853.0	1140.0	-
800	250	277.0	416.0	914.0	1501.0	1937.0	-
900	300	386.0	733.0	1330.0	2082.0	2689.0	-
1000	300	531.0	991.0	1751.0	2945.0	3700.0	-

*1 Building length 130 mm

*2 Building length 260 mm

Warning: Deviations (+/-25 %) in the stiffness torque may occur due to use of different materials and manufacturing processes.

Frictional force

DN	Length BL mm	For designs E and M	For design F
		Frictional force N/bar	Frictional torque Nm/bar
20	*1125	7	0.2
25	*1125	7	0.2
32	*1125	7	0.2
40	*1125	8	0.2
50	*1125	12	0.3
65	*1125	20	0.5
80	150	30	1.0
100	150	44	1.4
125	150	65	2.1
150	150	102	4.4
200	175	124	6.2
250	175	180	11.2
300	200	218	15.4
350	200	120	17.0
400	200	160	22.9
450	250	226	40.5
700	*2275	602	180.9
800	250	814	326.2
900	300	921	402.4
1000	300	1130	617.3

*1 Building length 130 mm

*2 Building length 260 mm

Warning: Deviations (+/-25 %) in the frictional force/torque may occur due to use of different materials and manufacturing processes.

WILLBRANDT Rubber Expansion Joint Type 55 SO for Shock Design

■ mainly in stock

DN 20 to DN 300

The type 55 SO is a low corrugated, highly elastic rubber expansion joint. Its flat corrugated shape minimises flow resistance. It has been specially designed for the shipbuilding industry and is characterised by its high shock expansion absorption.

Type 55 SO is primarily used in naval shipbuilding, where it is used to absorb movement and vibrations and to dampen noise, while at the same time protecting the connected units in the event of a shock.

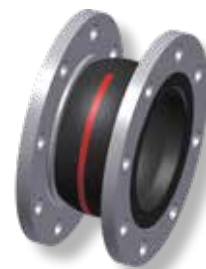

Bellow design	Low corrugated rubber bellow with reinforcement and shaped sealing bead with core ring, self-sealing (no additional seals required). Suitable for swiveling flanges.	Vacuum resistance	- DN 20 to 50 vakuüm-proof - DN 65 to 250 up to -200 mbar - DN 300 to 1000 not vacuum-proof - With vacuum supporting spiral/ring from DN 65 to 1000 vacuum-proof
Flange version	Both sides with swiveling flange made of galvanized steel, drilled according to DIN PN 10 (standard). Other materials and dimensions are possible.	Accessories	- Tie rods - Vacuum supporting spiral/rings - Guide sleeves - PTFE lining (see type 55 PTFE on page 66) - Potential equalisation - Flame-resistant protective covers - Dust and splash protection covers - Earth cover / sun protection cover Further information on page 99 - 105.
Approvals/Conformity	CE, drinking water conform, shipbuilding approvals, TÜV tested in accordance with DIN 4809 (Detailed overview on page 5.)		

Specifications

Bellow		Bellow design			Permissible operating data								Surface resistance Ro		
Colour code	Colour marking	Core (inner)	Reinforcement	Cover (outer)	°C		bar		°C		bar		Short-term °C	Core	Cover
red Sp		EPDM	PEEK	EPDM	-40	10	70	16	100	10	130	8	150	dissipative	dissipative
red		IIR	Polyamide	EPDM	-40	10	50	16	70	12	100	10	120	dissipative	dissipative
yellow		NBR	Polyamide	CR	-20	10	50	16	70	12	90	10	100	conductive	conductive

Bursting pressure for DN 20 - DN 300: > 48 bar
DN 250 and DN 300 max. 10 bar operating pressure / bursting pressure 30 bar

Application

Type 55 SO red Sp

For heating installations according to DIN 4809. For many years of operation under constant loading with hot water and heating water at 100 °C/110 °C at 10 bar/6 bar operating pressure. Electrically dissipative surface. Not suitable for media with additives containing oil.

alkalis, salt solutions, technical alcohols, esters and ketones. Electrically dissipative surface. Not suitable for oil products or cooling water with additives containing oil.

Type 55 SO red

For drinking water, hot water, sea water, cooling water with glycol or other chemical additives for water treatment, weak acids,

Type 55 SO yellow

For oils, lubricants, fuels, gases, city and natural gas (not liquefied) and DIN EN fuels with an aromatic content up to 50 %. Electrically conductive surface.

Important information

The expansion joints are designed for connection to a flange in accordance with EN 1092-1, form A/B, type 11. If the flange dimensions or surface finish differ from this, additional measures must be taken, such as installing an adapter disc (see also table „Rubber bellow sealing profiles“ on page 117).

For aggressive media, please have the material resistance checked by our engineers. The bellows must not be painted or insulated at media temperatures >50 °C. Please also note the planning instructions.

WILLBRANDT Rubber Expansion Joint Type 55 SO for Shock Design

Design A - without tie rods

Can be used for absorb movements in all directions (for combined movements, refer to the movement diagram in the technical appendix), for vibration and noise damping.

The expansion joint's reaction force must be absorbed through appropriate pipeline guidance (see planning instructions in the appendix).

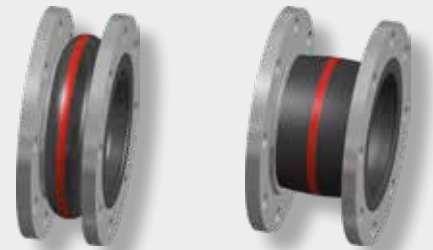
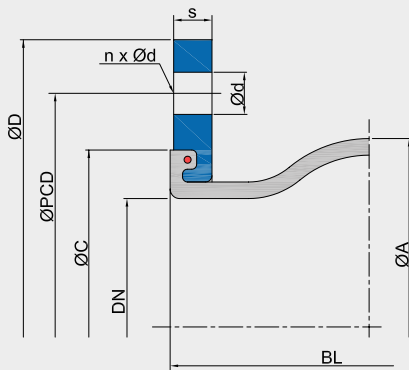

axial -

axial +

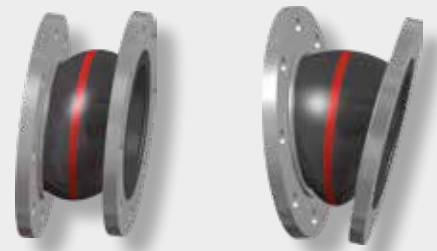

lateral ±

angular ±

Dimensions for design A

DN	Length BL	Bellow		Flange PN 10*2						Movement absorption*3				Weight*4
		ØA	WF*1	ØD	ØPCD	Ød	n	s	ØC	axial + mm	axial - mm	lateral ± mm	angular ± ∠°	
20	160	81	1700	105	75	M12	4	14	66	35	30	35	15	1.6
25	160	81	1700	115	85	14	4	14	66	35	30	35	15	1.8
32	160	81	1700	140	100	18	4	15	66	35	30	35	15	2.9
40	160	86	1800	150	110	18	4	15	74	35	30	35	15	3.5
50	160	96	3200	165	125	18	4	16	86	35	30	35	15	4.5
65	160	111	5300	185	145	18	8	16	106	35	30	35	15	5.3
80	160	122	8500	200	160	18	8	18	118	35	30	35	15	6.7
100	160	142	12800	220	180	18	8	18	138	35	30	35	15	7.7
125	160	168	18700	250	210	18	8	18	166	35	30	35	15	9.4
150	160	192	25900	285	240	22	8	18	192	35	30	35	15	11.9
200	160	252	41000	340	295	22	8	20	252	35	30	35	15	16.2
250	200	302	59600	395	350	22	12	20	304	35	40	30	10	22.6
300	200	354	82200	445	400	22	12	22	354	35	40	30	10	27.7

*1 WF = effective area

*2 Other standards/dimensions possible.

*3 Utilisation rate of movement absorption decreases at higher temperatures (see technical appendix).

*4 Approx. weights with reinforcement from polyamide cord.

Shock absorption in any direction ±50 mm

Important information

Please note the appropriate fixed point constructions and plain bearings in your piping system! Information on this can be found in our planning instructions.

Regarding the bracing, please refer to the information in the technical appendix (page 99 - 102)!



WILLBRANDT Rubber Expansion Joint Type 55 PTFE

■ not in stock

DN 25 to DN 700

Type 55 PTFE is a low corrugated rubber expansion joint lined with PTFE. Its low corrugation minimises flow resistance. The PTFE lining gives the expansion joint good anti-adhesive properties and is chemically resistant.

The PTFE lining can be used with any type 55 rubber compound. However, it is important to ensure that the selected rubber compound achieves the highest possible resistance to the medium, as this is the only way to achieve an optimum service life.



Dimensions for design A

DN*1	Length BL	Bellow		ØD	ØPCD	Flange PN 10*3			ØC	Movement absorption			
		ØA	WF*2			Ød	n	s		axial + mm	axial - mm	lateral ± mm	angular ±
25	*4125	81	1700	115	85	14	4	14	65	15	15	15	15
32	*4125	81	1700	140	100	18	4	15	65	15	15	15	15
40	*4125	86	1800	150	110	18	4	15	74	15	15	15	15
50	*4125	96	3200	165	125	18	4	16	86	15	15	15	15
65	*4125	111	5300	185	145	18	8	16	105	15	15	15	15
80	150	122	8500	200	160	18	8	18	118	15	15	15	15
100	150	142	12800	220	180	18	8	18	137	15	15	15	10
125	150	168	18700	250	210	18	8	18	166	15	15	15	10
150	150	192	25900	285	240	22	8	20	192	15	15	15	10
200	175	252	41000	340	295	22	8	20	252	15	15	15	6
250	175	302	59600	395	350	22	12	20	304	15	15	15	6
300	200	354	82200	445	400	22	12	20	354	15	15	15	6
350	200	420	117600	505	460	22	16	24	412	15	15	15	4
400	200	480	154700	565	515	26	16	25	470	15	15	15	4
*5450	250	530	204200	615	565	26	20	25	520	15	15	15	4
*6500	-	-	-	-	-	-	-	-	-	-	-	-	-
*6600	-	-	-	-	-	-	-	-	-	-	-	-	-
700	*7275	800	434200	895	840	30	24	35	780	15	15	15	4

*1 For larger nominal diameters, feasibility must be checked.

*2 WF = effective area

*3 Other standards/dimensions possible.

*4 Building length 130 mm

*5 Only in colour code red (IIR) and yellow (NBR).

*6 See type 39 and type 52

*7 Building length 260 mm

Pressure resistance

Max. 6 bar operating pressure with polyamide cord reinforcement, max. 9 bar operating pressure with aramid or steel cord reinforcement.

Conformity

FDA and EG 1935/2004
(Detailed overview on page 5.)

Vacuum resistance

Only limited suitable for vacuum operation. A PTFE vacuum supporting ring, which allows full vacuum for small nominal diameters, can be used from DN 50.

The PTFE supporting ring can only be used up to 50 °C.
DN 25, DN 32, DN 40 and DN 350 expansion joints are not suitable for vacuum operation.

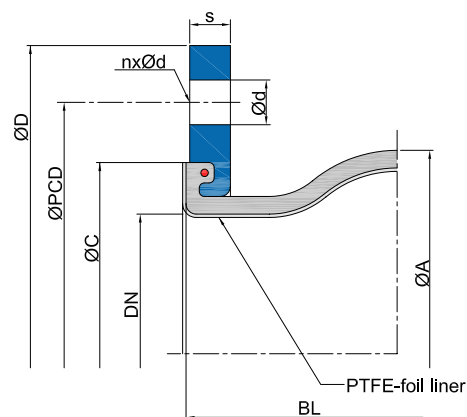

Important information

The expansion joints are designed for connection to a flange in accordance with EN 1092-1, form A/B, type 11. If the flange dimensions or surface finish differ from this, additional measures must be taken, such as installing an adapter disc (see also table „Rubber bellow sealing profiles“ on page 117).

Rubber expansion joints with PTFE lining are not suitable for absorbing vibrations. The bellows must not be painted or insulated at media temperatures >50 °C. Please also note the planning instructions.